

JVC

D-ILA Projectors

DLA-NZ900, DLA-NZ800, DLA-NZ700, DLA-NZ500

D-ILA

The ART of PROJECTION
A True Cinematic Experience



*For more information on the new D-ILA projectors, scan or click
on the QR code to access the Official Website*

D-ILA The ART of PROJECTION



8K Home Theater Projectors

8K
e-shift X



D-ILA home theater projectors in remarkable 8K resolution were made possible with over a quarter century of JVC engineering and technology. Discover the art of projection.



DLA-NZ900

D-ILA *BLU Escent Laser* **HDR** **HDR10+** **PURECOLOR 4K**

100mm HQ Lens

Native contrast 150,000:1, Peak brightness: 3,300 lumens



DLA-NZ800

D-ILA *BLU Escent Laser* **HDR** **HDR10+** **PURECOLOR 4K**

Native contrast 100,000:1, Peak brightness: 2,700 lumens

VISION A True Cinematic Experience



Native 4K Home Theater Projectors

4K

All new native 4K resolution models featuring the world's smallest body* satisfy a wider group of users with solid quality. Encounter a true cinematic experience.

*As of August 2025 for projectors featuring native 4K panel.



DLA-NZ700

DILA *BLU Escent Laser* **HDR** **HDR10+**



Native contrast 80,000:1, Peak brightness: 2,300 lumens



DLA-NZ500

DILA *BLU Escent Laser* **HDR** **HDR10+**



Native contrast 40,000:1, Peak brightness: 2,000 lumens

Delivers smooth and realistic 8K images rich in colors and brightness. Enjoy a high-quality visual experience with enhanced dimensionality and immersiveness.

8K
8192 x 4320 pixels

Exceptional Contrast

Third-generation, Native 4K D-ILA Device

D-ILA device is the heart of projectors that plays an important role in projecting beautiful images. Device perfection continues to date – the third generation (Gen3) 0.69-inch native 4K D-ILA device has improved its alignment control of liquid crystals and enhanced the flatness of image pixels to offer 1.5-times* the native contrast ratio on the DLA-NZ900 compared to the Gen2 device.

*1.25-times on the DLA-NZ800

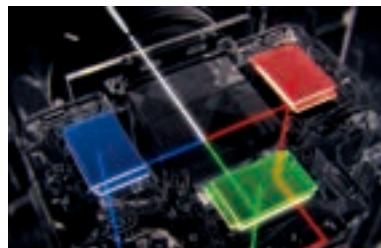

4K D-ILA

Unparalleled Black Level and High Luminance

The DLA-NZ900 boasts the industry's highest native contrast of 150,000:1 with the Gen3 0.69-inch 4K D-ILA device and wire-grid optical engine, however in combination with the dynamic laser light control, which analyzes the incoming video signal to automatically control the amount of outgoing laser light, a dynamic contrast level of ∞ :1 (infinity to 1) can be achieved in scenes with pitch blackness by completely shutting off the light source.



Starry sky with a sense of contrast

High Brightness

Light Source for Exceptional Brightness

Another essential aspect of projectors lies in their light source. JVC's D-ILA projectors feature "BLU-Escent Laser" light source to achieve exceptional peak brightness of 3,300 lumens on the DLA-NZ900 and 2,700 lumens on the DLA-NZ800, both with longevity of 20,000 hours. Power efficiency improvements made on the BLU-Escent Laser also contributes to saving power.



Superior Resolution

8K Resolution Display with Gen2 8K/e-shiftX

Combining "e-shift technology" – a high-resolution display technology that doubles the resolution by shifting a pixel by 0.5 pixels in four directions up, down, left, and right – and "native 4K D-ILA devices", the second generation 8K/e-shiftX has made significant progress. Featuring the latest scaling engine, the Gen2 8K/e-shiftX drastically improves the projector's sharpness and detail across a wide range of content.



See how the native 4K image becomes sharper as if it is alive with the newest 8K/e-shiftX processing.

All-glass Lens System Designed for the 8K Projectors

The DLA-NZ900 is equipped with an 18-element, 16-group 100-mm all-glass lens* featuring a full aluminum lens barrel. To project high-resolution 8K images to every corner of the screen, the projector incorporates five ED lenses calibrated for differences in the R/G/B refractive index to reduce chromatic aberration and color fringing when lens shift kicks in to deliver precise reproduction of 4K- or 8K-resolution projection.

*The DLA-NZ800 features 17-element, 15-group 65-mm all-glass lens without ED lenses.

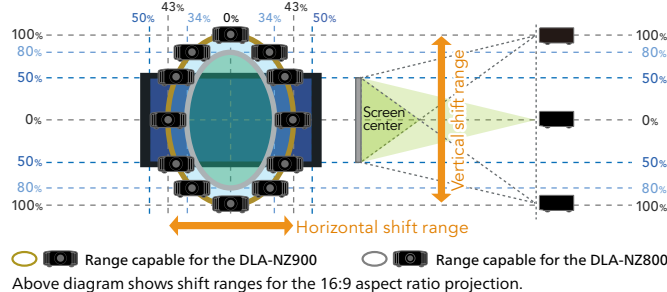

Supports a Variety of Inputs Including 8K60p and 4K120p

The 8K projectors support full 48Gbps 8K60p and 4K120p. The latest LSIs process four times the amount of information from input to D-ILA device instantly and enable enjoyment of stable high-quality 8K images at all times. The 4K120p input makes these projectors ideal for displaying game content on large screens.

New ALLM (Auto Low Latency Mode)*

Ideal for gaming content, ALLM kicks in automatically after detecting the video signal from a connected device to improve the gaming experience on a big screen for greater immersion.

* Features such as Frame Adapt HDR, Laser Dynamic Control, and Clear Motion Drive are not available while ALLM is in use.

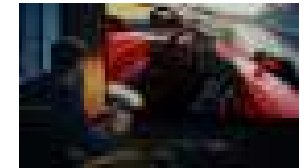

New Enhanced Multiple Pixel Control (MPC) Technology

We succeeded in achieving more natural and realistic picture portraiture after a thorough review of Standard mode on our original super-resolution processing technology Multiple Pixel Control (MPC). Plus, with the new Smoother function, which effectively controls the "banding artifact" generated as a result of video data compression, much more realistic and smoother 8K image can be expressed while maintaining a sense of high definition with a natural feel. Even in images that require precise details and gradation, the function reduces unwanted distortions to heighten the quality of your visual experience.

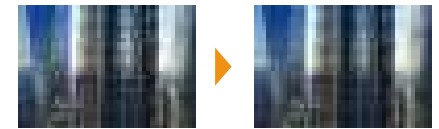

New Standard mode achieves natural, realistic high-resolution images



New Smoother function suppresses banding artifacts

Refined Sleek Design, Native 4K, BLU-Escent Laser
Discover Your Next Cinematic Journey



Native **4K**

4096 x 2160 pixels



Compact Design

World's Smallest* Native 4K Projectors

Completely redesigned with a new chassis, optical units, lens system, and circuit boards, the DLA-NZ700 and NZ500 are the world's smallest native 4K projectors*. While maintaining a small footprint, these models incorporate JVC's proprietary BLU-Escent laser light source and native 4K devices found on the DLA-NZ900 and NZ800. The horizontal grille on the front panel expresses the center lens in a symbolic manner, while the rounded corners of the body emphasize user-friendliness. What's more, the DLA-NZ500 comes available in two colors of black and white to match any interior settings.

*As of August 2025 for projectors featuring native 4K panel.

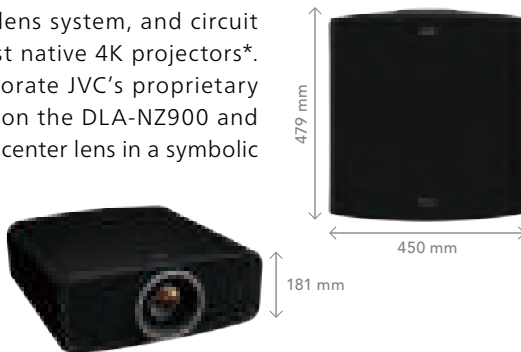

Superb Intake/Exhaust Layout

A straight cooling system that draws air in from the front and exhausts it out the back has been applied on the DLA-NZ700/NZ500 to emphasize compactness of the body, reduce the impact from heat on the projection screen and enable greater flexibility in installation.



Intake draws in air from the front and exhaust releases hot air from the rear.

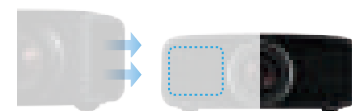

On the DLA-NZ900 and NZ800, exhaust releases air from the front towards the sides, whereas the newly designed straight cooling system draws air in from the front.

Native 4K Projection

Pixel Perfect Resolution with Native 4K Input and 4K D-ILA Device

Signals input via the 32Gbps 4K/60p HDMI terminal go through the third generation (Gen3)* 0.69-inch native 4K D-ILA devices to project full native 4K (4,096 x 2,160 pixels) resolution images on the screen with uniform brightness and more subtle blacks. With the combination of native 4K input and device, improved overall image quality can be achieved.

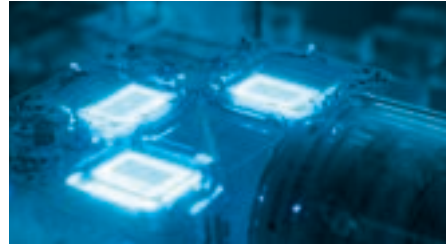

4K D-ILA

*Only on the DLA-NZ700

Unbeatable Black Level and High Luminance

Native contrast of 80,000:1* with dynamic contrast of ∞ :1 (infinity to 1) on the DLA-NZ700 is realized with the combination of the latest 0.69-inch native 4K D-ILA device with wire-grid optical engine and the BLU-Escent laser light source with dynamic laser light control. As a result, images brimming with reality can be achieved.



* DLA-NZ500 offers native contrast of 40,000:1.

New BLU-Escent Laser and 4K Lens System

BLU-Escent Laser for Remarkably Bright Images

JVC's proprietary "BLU-Escent Laser" light source designed exclusively for the new models is featured to achieve exceptional peak brightness of 2,300 lumens on the DLA-NZ700 and 2,000 lumens on the DLA-NZ500, both with longevity of 20,000 hours.

BLU-Escent Laser



Controlling the Luminance on BLU-Escent Laser

Luminance of projectors equipped with BLU-Escent Laser can be finely adjusted according to the environment and preference using the Light Source Control with a total of 101 (0 - 100) luminance control steps.

101 luminance control steps (0 - 100 steps)

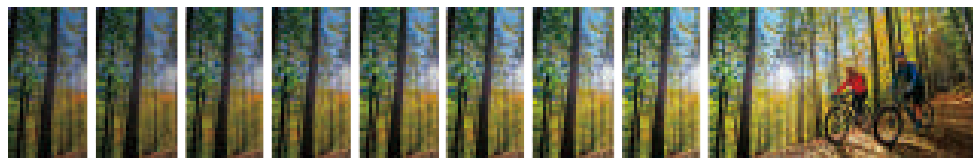

0 ← → 100

New Fully Motorized 4K Lens

The newly introduced compact projectors feature native 4K lens with a 15-element, 11-group, 80-mm lens with motorized focus, zoom, and shift for faithful reproduction of distortion-free, high-resolution native 4K images. In addition to a wide lens shift range of 70% vertical and 28% horizontal, these projectors are equipped with a 1.6x zoom that enables a projection distance of 3 meters at 100 inches, making these flexible for a variety of installation environments without sacrificing image quality. Its Lens Memory function comes in handy when switching between conventional 16:9- and cinemascope-sized screens.



15-element, 11-group 80-mm lens

80mm



Lens shift function:
70 % vertical, 28 % horizontal

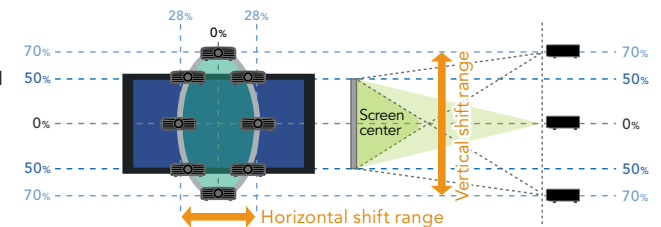

Above diagram shows shift ranges for the 16:9 aspect ratio projection.

Projecting a Diverse Range of HDR Sources



Frame Adapt HDR Drastically Enhances the Beauty of HDR Format Images

D-ILA projectors support all HDR formats from HDR10 to HLG for broadcasting, and the HDR10+ with dynamic metadata compatibility. The Gen2 Frame Adapt HDR function instantaneously analyzes the maximum brightness of an HDR content per scene or frame and performs real-time tone mapping to optimize the dynamic range for high-definition video projection. As a result, brighter and more colorful HDR images with a wider dynamic range are reproduced.



NZ900 NZ800

New HDR Vivid Picture Mode, Offering Both Vividness and Contrast

With the latest firmware update on the 8K projectors*, Frame Adapt HDR now features the HDR Vivid picture mode. Based on the PQ (Perceptual Quantizer) curve data, this mode realizes a picture bursting with reality by improving the detail in the lighter areas and darkening the darker areas to increase the sense of contrast and saturation of the entire image. This allows subjects to stand out naturally, achieving images with a sense of depth.

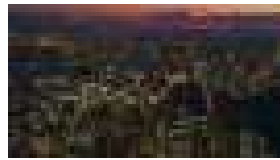

Conventional

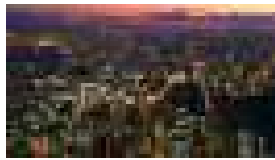

Frame Adapt HDR Vivid

* For the latest firmware update, access from the QR code on p9.

Vivid Reproduction of HDR Sources Containing Wide Color Gamut

Even when HDR content using a wide color gamut equivalent to BT.709 and DCI-P3* is projected on these projectors, the original cinema filter combined with the BLU-Escent Laser work together to reproduce rich colors, such as the gradations of the sky and ocean, the contrast of red roses, or a row of fresh green trees.

* The DLA-NZ500 supports 100% sRGB.

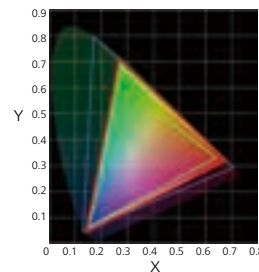

— DLA-NZ900/NZ800/NZ700 — BT.709 (sRGB) — DCI — BT.2020

Deeper Blacks for Richer Gradation

The Deep Black Tone Control on the Gen2 Frame Adapt HDR with a new algorithm further subdues tones in dark areas to achieve more realistic darkness. This function maximizes the dynamic range of the 4K D-ILA devices and delivers images with more contrast than ever before. Scenes with light and dark shades such as nightscapes can be projected with greater realism.



Conventional



New Deep Black Tone Control

New Highlight Color Control Function to Portray Scenes with High Brightness

NZ900 NZ800

A new image quality mode called Highlight Color Control function in Frame Adapt HDR optimizes the balance between the sense of brightness and saturation in scenes with high intensity where colors tend to fade out. Selectable from Low, Mid and High to perform flexible adjustment matching the viewing environment, user preferences and content characteristics. When used together with the new HDR Vivid mode, HDR images with vivid detail and dynamic contrast can be achieved for scenes with high contrast.



Low

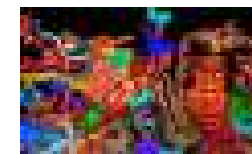

Mid

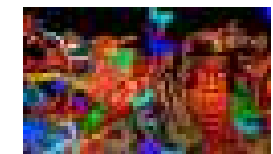

High

DML (Display Mastering Luminance) for Better HDR Experience

DML (Max Display Mastering Luminance) metadata, which represents the nit level of the professional monitor used to grade the movie to the director's standards, is used to set the dynamic range of the title for improved HDR tone mapping. Both DML and MaxCLL values are used for the HDR levels.

Projecting the Content More Beautifully and Faithfully

Vivid Mode Projects SDR Content with Greater Vividness

To reproduce content with a narrow dynamic range in more saturated colors, conventional Natural mode has been improved to "Vivid" mode. This mode is excellent for projecting classic SDR works with greater vividness that are yet popular in streaming content.



Conventional Natural Mode



Vivid Mode

New

New Convenient Features Added to the 8K Projectors NZ900 NZ800

- OSD Guide function allows users to adjust fine and advanced settings such as HDR and color while checking each step using the guide.



Select a feature to show its description in a popup window
Detailed description under Information

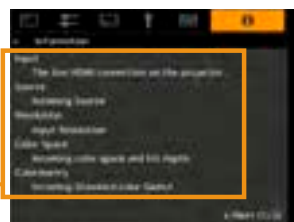

- New OSD Brightness-Linked Mode minimizes changes of the on-screen display brightness, even while the light source is controlling the dynamic brightness, to deliver the appropriate brightness. The mode can be switched on or off, allowing flexible settings according to the usage environment or preferences.

- Calibrator Mode, which is newly featured on the calibration software, is used to calibrate settings such as color temperature and color gamut for expert-level, high-precision image tuning.



- Advanced Menu Key on the remote allows the projector to memorize user-preference settings and call them up as needed.



Recreating the Creator's Original Intentions

FILMMAKER MODE™ was developed by the UHD Alliance with the aim of faithfully reproducing the filmmakers' intentions in the home. When using the mode, picture quality adjustments such as frame interpolation and noise reduction are turned off, and the color temperature is set to D65 (6500K), allowing users to enjoy movies and documentaries with picture quality that is faithful to the original master.

Other Features

- Ultra-high Contrast Optics not only contributes to achieving high optical brightness, but also suppresses the return of unnecessary light to the projection screen for clear and colorful images.
- Auto Calibration function that uses an optical sensor with proprietary software* optimizing all essential elements found in the image, including color balance, gamma characteristics, etc. that change according to installation and usage conditions.

*Optional optical sensor and proprietary software, PC, and LAN cable are required to perform auto calibration function.

- Installation Mode: The DLA-NZ900 and NZ800 models allow user to centrally manage 8 settings such as Lens Control, and Pixel Adjustment. A total of 10 different mode settings can be named, stored and called up. On the DLA-NZ700 and NZ500 models, up to 5 settings including Lens Memory, Pixel Adjustment, and Screen Mask can be stored and called up.

- More than 200 Screen Adjustment modes can be used to correct imbalances caused by screen characteristics.



Information

Scan/Click on the QR Code to Access:

Free firmware download



Official Website of the new D-ILA projectors



Screen adjustment mode table



● Specifications

| GENERAL | | DLA-NZ900 | DLA-NZ800 | DLA-NZ700 | DLA-NZ500 |
|---|------------------|--|--------------------------|--------------------------------------|---|
| Device | | 0.69-inch Native 4K D-ILA Device (4096 x 2160) x3 | | | |
| Display Resolution | | 8192 x 4320 (Gen2 8K/e-shiftX) | | 4096 x 2160 (Native) | |
| Lens | Type | x2 motorized zoom & focus, all-glass lens | | | x1.6 motorized zoom & focus, native 4K lens |
| | Diameter | 100 mm | 65 mm | 80 mm | |
| Lens Shift (motorized in 16:9 aspect ratio) | Vertical | ±100% | ±80% | ±70% | |
| | Horizontal | ±43% | ±34% | ±28% | |
| Projection Display Size (diagonal) | | 60 inch – 300 inch | | 60 inch – 200 inch | |
| Light Source | | BLU-Escent Laser diode | | | |
| Brightness | | 3,300 lm | 2,700 lm | 2,300 lm | 2,000 lm |
| Contrast Ratio | Dynamic | ∞:1 | | | |
| | Native | 150,000:1 | 100,000:1 | 80,000:1 | 40,000:1 |
| Cinema Filter (Color Gamut) | | DCI 98%/BT.2020 73% | | | sRGB 100% |
| Input Terminal | HDMI | 2 (48 Gbps/HDCP 2.3, no CEC support) | | 2 (32 Gbps/HDCP 2.3, no CEC support) | |
| Output Terminal | TRIGGER | 1 (Mini Jack, DC 12 V/100 mA) | | | — |
| | 3D SYNCHRO | 1 (Mini Din 3-pin) | | | — |
| Control Terminal | RS 232C | 1 (D-sub 9pin) | | | — |
| | LAN | 1 (RJ45) | | | |
| Service Terminal | SERVICE | 1 (USB Type A) for firmware update and backing up settings | | | |
| Power Consumption | Projector in Use | 440 W | | 280W | |
| | Eco-mode Standby | | | 0.3 W | |
| | Standby | | | 1.5 W | |
| Fan Noise | | 24 dB (LD power at minimum) | | 23 dB (LD power at minimum) | |
| Power Requirement | | AC 100-240V, 50/60Hz | | | |
| Dimensions (W x H x D, including feet) | | 500 mm x 234 mm x 528 mm | 500 mm x 234 mm x 505 mm | 450 mm x 181 mm x 479 mm | |
| Weight (net) | | 25.3 kg | 23.1 kg | 14.8 kg | 14.6 kg |

| FEATURES | | DLA-NZ900 | DLA-NZ800 | DLA-NZ700 | DLA-NZ500 |
|---|-------------------------|---------------------------|--|---------------------|-----------|
| Max Input | | 80K60p and 4K120p | | | 4K60p |
| Light Source Control by Slider Adjustment | | | | | 101 steps |
| Multiple Pixel Control (MPC) | | New MPC | | | MPC |
| Ultra-High Contrast Optics | | | | | |
| HDR | HDR10+/HDR/HLG | • | | | |
| | Mastering Info Display | • (Max CLL/Max FALL/DML) | | | |
| | Frame Adapt HDR Gen2 | • | | | |
| | Deep Black Tone Control | • | | | |
| | Theater Optimizer | • | | | |
| | HDR Vivid Mode | • | | | |
| | Highlight Color Control | • | | | |
| Vivid Mode (for SDR signals) | | • | | | |
| FILMMAKER MODE™ | | • | | | |
| 3D Support | | • | | | |
| Clear Motion Drive | | • | • (black frame insertion at 60Hz input only) | | |
| Motion Enhance | | • | | | |
| ALLM (Auto Low Latency Mode)* | | • (switch On/Off via OSD) | | — | |
| Low Latency Mode | | • (switch On/Off via OSD) | | — | |
| Auto Calibration | | • | | | |
| Installation Mode | | • (max. 10 memories) | | • (max. 5 memories) | |
| OSD Guide | | • | | | |
| OSD Brightness-Linked Mode | | • | | | |
| USB Back-up | | • | | | |

* Features such as Frame Adapt HDR, Laser Dynamic Control, and Clear Motion Drive are not available while ALLM is in use.
Note: Values are typical. Depends on the projector setting conditions and usage environment.

● External Dimensions

Unit: (mm)

DLA-NZ900

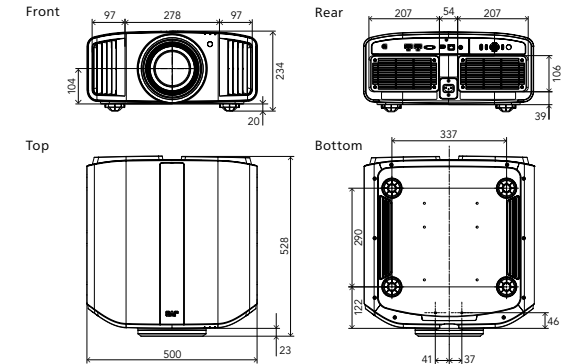

DLA-NZ800

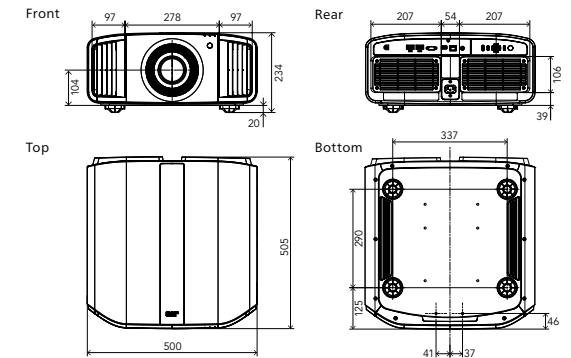

DLA-NZ700/NZ500

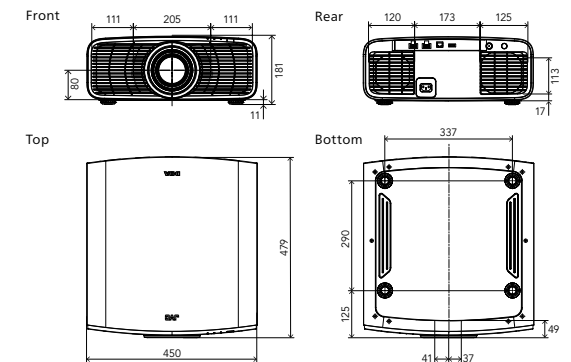

● Projection Distance Chart

DLA-NZ900

| Screen diagonal (inch) | Screen size aspect ratio: 16:9 | | | | Screen size aspect ratio: 2.4:1 (Cinematic) | | | |
|------------------------|--------------------------------|-------------|---------------------|----------|---|-------------|---------------------|----------|
| | Screen size | | Projection distance | | Screen size | | Projection distance | |
| | Width (mm) | Height (mm) | Wide (m) | Tele (m) | Width (mm) | Height (mm) | Wide (m) | Tele (m) |
| 60 | 1,328 | 747 | 1.75 | 3.61 | 1,402 | 586 | 1.86 | 3.83 |
| 90 | 1,992 | 1,121 | 2.67 | 5.46 | 2,103 | 879 | 2.83 | 5.78 |
| 100 | 2,214 | 1,245 | 2.98 | 6.07 | 2,337 | 977 | 3.16 | 6.43 |
| 110 | 2,435 | 1,370 | 3.28 | 6.69 | 2,571 | 1,075 | 3.48 | 7.09 |
| 120 | 2,657 | 1,494 | 3.59 | 7.30 | 2,805 | 1,172 | 3.81 | 7.74 |
| 150 | 3,321 | 1,868 | 4.51 | 9.15 | 3,506 | 1,465 | 4.78 | 9.69 |
| 200 | 4,428 | 2,491 | 6.04 | 12.22 | 4,674 | 1,954 | 6.40 | 12.95 |
| 250 | 5,535 | 3,113 | 7.57 | 15.30 | 5,843 | 2,442 | 8.02 | 16.20 |
| 280 | 6,199 | 3,487 | 8.48 | 17.14 | — | — | — | — |

Note: Projection distances are design specifications, so there is ±5% variation.

DLA-NZ800

| Screen diagonal (inch) | Screen size aspect ratio: 16:9 | | | | Screen size aspect ratio: 2.4:1 (Cinematic) | | | |
|------------------------|--------------------------------|-------------|---------------------|----------|---|-------------|---------------------|----------|
| | Screen size | | Projection distance | | Screen size | | Projection distance | |
| | Width (mm) | Height (mm) | Wide (m) | Tele (m) | Width (mm) | Height (mm) | Wide (m) | Tele (m) |
| 60 | 1,328 | 747 | 1.88 | 3.85 | 1,402 | 586 | 1.99 | 4.08 |
| 90 | 1,992 | 1,121 | 2.84 | 5.80 | 2,103 | 879 | 3.01 | 6.15 |
| 100 | 2,214 | 1,245 | 3.16 | 6.45 | 2,337 | 977 | 3.35 | 6.83 |
| 110 | 2,435 | 1,370 | 3.49 | 7.10 | 2,571 | 1,075 | 3.69 | 7.52 |
| 120 | 2,657 | 1,494 | 3.81 | 7.75 | 2,805 | 1,172 | 4.03 | 8.21 |
| 150 | 3,321 | 1,868 | 4.77 | 9.70 | 3,506 | 1,465 | 5.05 | 10.27 |
| 200 | 4,428 | 2,491 | 6.38 | 12.95 | — | — | — | — |

Note: Projection distances are design specifications, so there is ±5% variation.

DLA-NZ700/NZ500

| Screen diagonal (inch) | Screen size aspect ratio: 16:9 | | | | Screen size aspect ratio: 2.4:1 (Cinematic) | | | |
|------------------------|--------------------------------|-------------|---------------------|----------|---|-------------|---------------------|----------|
| | Screen size | | Projection distance | | Screen size | | Projection distance | |
| | Width (mm) | Height (mm) | Wide (m) | Tele (m) | Width (mm) | Height (mm) | Wide (m) | Tele (m) |
| 60 | 1,328 | 747 | 1.77 | 2.85 | 1,407 | 586 | 1.87 | 3.03 |
| 90 | 1,992 | 1,121 | 2.68 | 4.31 | 2,110 | 879 | 2.84 | 4.56 |
| 100 | 2,214 | 1,245 | 2.98 | 4.79 | 2,345 | 977 | 3.16 | 5.08 |
| 110 | 2,435 | 1,370 | 3.28 | 5.28 | 2,579 | 1,075 | 3.48 | 5.59 |
| 120 | 2,657 | 1,494 | 3.58 | 5.76 | 2,814 | 1,172 | 3.80 | 6.10 |
| 150 | 3,321 | 1,868 | 4.49 | 7.21 | 3,517 | 1,465 | 4.76 | 7.64 |
| 200 | 4,428 | 2,491 | 6.01 | 9.63 | 4,689 | 1,954 | 6.37 | 10.21 |

Note: Projection distances are design specifications, so there is ±5% variation.

● Optional Accessory



PK-EM2

3D RF Emitter

Signal reaches to 10 meters. No IR signal interruption with other equipment. No limitation to the number of the glasses.

● Connectors

DLA-NZ900/NZ800

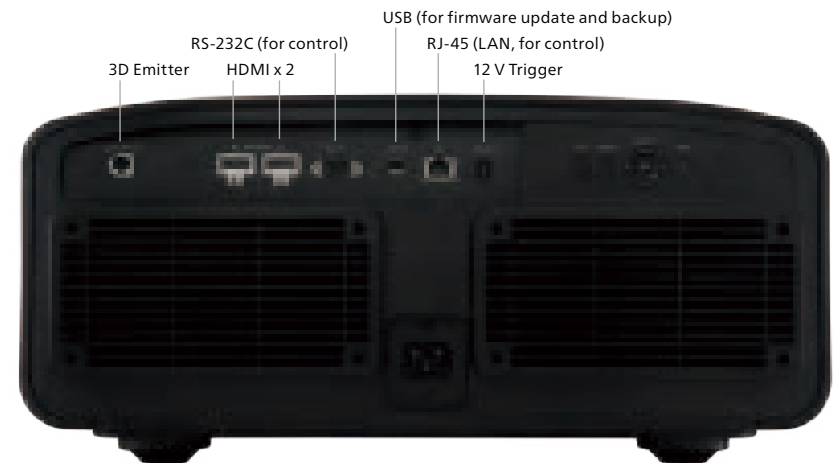

DLA-NZ700/NZ500

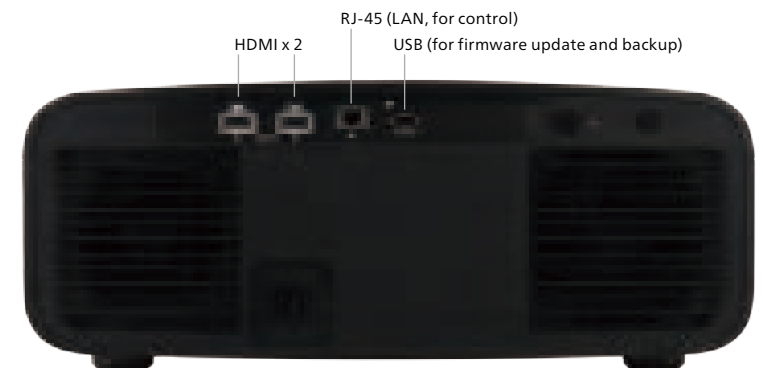

D-ILA The ART of PROJECTION A True Cinematic Experience



• D-ILA, e-shift, and BLU-Escent Laser are registered trademarks of JVCKENWOOD Corporation. • FILMMAKER MODE™ logo and its trade name are registered trademarks of UHD Alliance, Inc. in the US and other countries. • HDR10+™ logo is a trademark of HDR10+ Technologies, LLC. • YouTube™ is a trademark or registered trademark of Google LLC. • ISF is a registered trademark of Imaging Science Foundation, Inc. • The terms HDMI, HDMI High-Definition Multimedia Interface, HDMI trade dress and the HDMI Logos are trademarks or registered trademarks of HDMI Licensing Administrator, Inc. • All other brand or product names may be trademarks and/or registered trademarks of their respective owners. • All pictures in this brochure are simulated. • Design and specifications are subject to change without notice. • Any rights not expressly granted herein are reserved.

Copyright © 2025, JVCKENWOOD Corporation. All Rights Reserved.

JVC

DISTRIBUTED BY

<https://eu.jvc.com/>
<http://www.jvc.net/>

PJC-2503EG
"JVC" is the trademark or registered trademark of JVCKENWOOD Corporation.