

## Instruction Manual

### Recessed-Ceiling Motorized Projector Lift

Applicable Model  
GPCK-MB1000B

#### Please read before installation:

Thank you for purchasing this product.  
Please read the instruction manual  
carefully to ensure this projector lift is  
suitable for your installation environment.

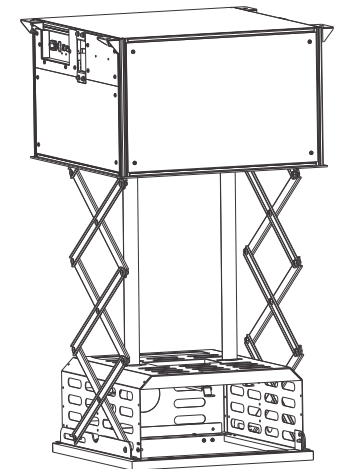

### Cautious



#### Warnings

This product should only be installed by a qualified technician.

Please review the manual carefully to ensure it is properly installation and to avoid injury.

The ceiling used must have a minimum load bearing of 12KG.



#### Caution

For projector lift assembly only



#### Do not take apart

Please do not take apart the  
accessories of mounting bracket

Grandview Crystal Screen Canada Ltd.

#11- 3751 North Fraser Way,  
Marine Way Business Centre,  
Burnaby, BC, Canada V5J 5G4  
Tel: 1-604-412-9777 Fax: 1-604-412-9796  
Website: www.grandviewscreen.ca

Guangzhou Grandview Crystal Screen Co., Ltd.

P.O. 511400 Federal Ind. Zone No. 363, Yushan West Road,  
Shiqiao, Panyu District, Guangzhou, Guangdong, China  
Tel: +8620-8489-9499 Fax: +8620-8480-3343  
Website: www.grandviewscreen.com



### Cautions for Location

- Please keep away from hot resources, dirty, high temperature and high humidity. Do not use the projector off the large wind.

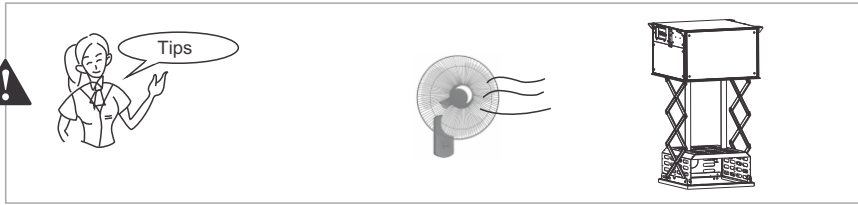

### Cautions for Repairing

- Please do not take apart the screws of the projector lift; if this product needs to be repaired, please contact our company or dealers.



### Questions & Answers

Grandview projector lift can be used for years, most problems are cost by simple incidents. If problem occurs, please find the list below for some common solutions. If problems keep on, please contact authorized agent of Grandview or call service number: (8620)84899499

	Reason	Solution
Projector Lift responds nothing to any operation	Battery mis-installed or powerless	Please check about the batteries with referring instruction manual.
	Power line disconnection	Please connect the power line with referring instruction manual.

#### Three years warranty

Grandview provides three years warranty for projector lift. Contents of warranty include replacement of spare parts while problems occur with correct operation. Not include inappropriately operating projector lift or uninstall the product by self. You should reserve in advance for the repair with Grandview or appointed service center.

### Caution

**Warnings:** Please prevent projector lift from wet place to avoid electric or fire dangerous.

1. Please read carefully with this instructions before installation to avoid damage to product causing by inappropriate installation or operation.
2. Please keep the projector lift away from hot sources, such as radiator, heating machine, fireplace, loudspeaker or other relative device.
3. Only Plug with ground wire is acceptable.
4. Only accessories from authorized supplier is acceptable.
5. Please unplug the power wire when lighting and raining or not use with a long time.
6. Please handle the repair work to the professional agent.
7. Please prevent screen from water as well as putting stuff with water (such as vase) on the screen.
8. As soon as the plug of the screen is connected to the power source, the screen is connecting with electricity.
9. Please use the approved power line (three-core power line)/ device interface/power plug.
10. Please use the rating (voltage, amps) power line (three-core power line) / device interface/power plug. If have any questions about power line/ device interface/power plug, please contact the professional people.
11. After installation, please locate a power device in order to disconnect power or connect the power plug to electrical socket. This electrical socket should be installed to a convenient position. If the accident occurs during operation, please disconnect power or take out the power plug.
12. The ceiling or wall used for fixture installation must be secure enough; load-bearing requirement must be 4 times of the projector lift to prevent the projector lift from falling.

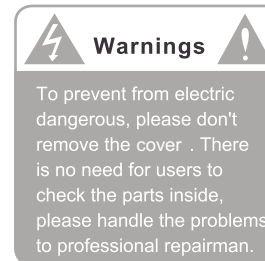

Please notice the non-insulated voltage of the spare parts to prevent from electric dangerous.



Please operate according to the instruction manual

#### Cleaning

Please clean the projector and projector lift at the same time.

## Accessories

- M4 Hexagonal Adjuster (1pc)
- M5、M4、M3×2 0mm Screw(each 4 pcs )



- Rubber Washer 0,5x10mm(4pcs)
- Controller(1pc)
- Battery (1set)



- Power Socket
- Instruction Manual

## Optional Accessories

- Wall-Switch(1pc)
- Multi-Media Box(1pc)



## Cautions

Please comply the following contents for installation and use

### Cautions

- Please do not shake the projector lift
- Please do not lift up the projector lift

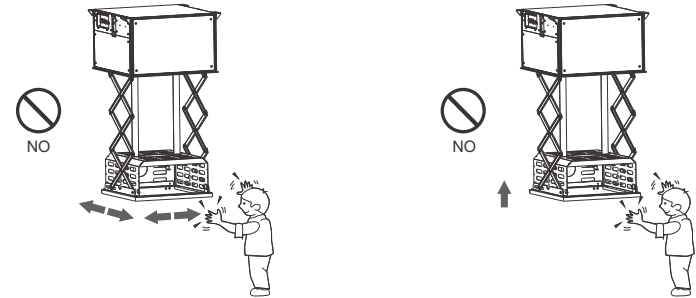

### Maintain

- Please clean the projector lift with dilute detergent slightly, and then dry up the lift. Use the soft hairbrush to clean the gap

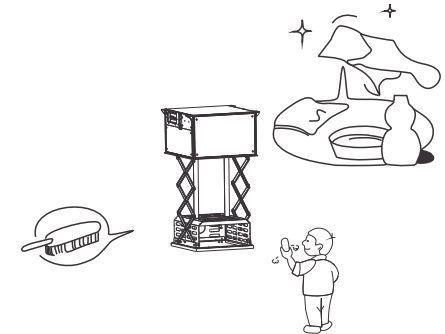

Kindly Reminder: Do not change the factory pre-settings for any urgency,pls operate according to the following instructions if necessary

## 2) Remote Localizer

a. When the projector lift is at loading situation, you can adjust the upper/lower limitation via the remote controller.

b. To press the localier hole at the back of the remote controller with one small pin or equivalence for about 3 seconds and the release, then press UP button for strap to the desired position and stop, the projector lift is already reset for its retract limit.

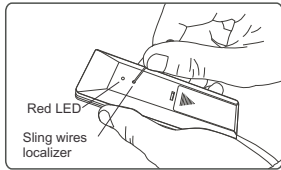

figure 16

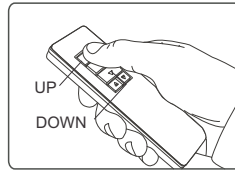

figure 17

c. To press the localier-hole at the back of the remote controller with one small pin or equivalence for about 3 seconds and release, then press DOWN button for strap to the desired position and stop, the projector lift is already reset for its retract limit.

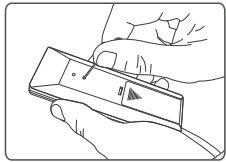

figure 18

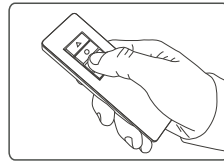

figure 19

⚠ Note: For ensuring the security of positioning function, the effective setting period of electric positioning should be 60 seconds, after 60 seconds will return to normal situation. If the setting fails within 60 seconds, please repeat as following step; to press the setting button; then LED light will turn off; press the setting button again, then LED light will turn on. In this movement, the resetting function will begin.

## Motor Positioning

Do not roll and retract the projector lift continuously over 4 minutes in a time to avoid overheating. If the motor overheats, keep 30 minutes for heat elimination. No lubrication needed for the motor, the drop and retract limit of the projector lift has been prepositioned to an optimal configuration before delivery. In order to avoid motor damage, please ask the local dealer or professional for consultation when a new position setting is needed.

Use the M4 allen-key for adjusting the upper and lower limitation of projector lift, but the distance can not be over than the value D in specification table.

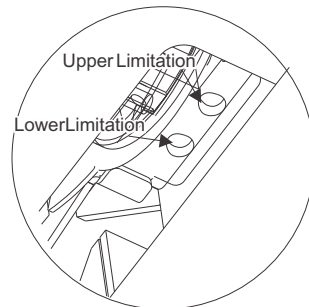

## Construction for Projector Lift

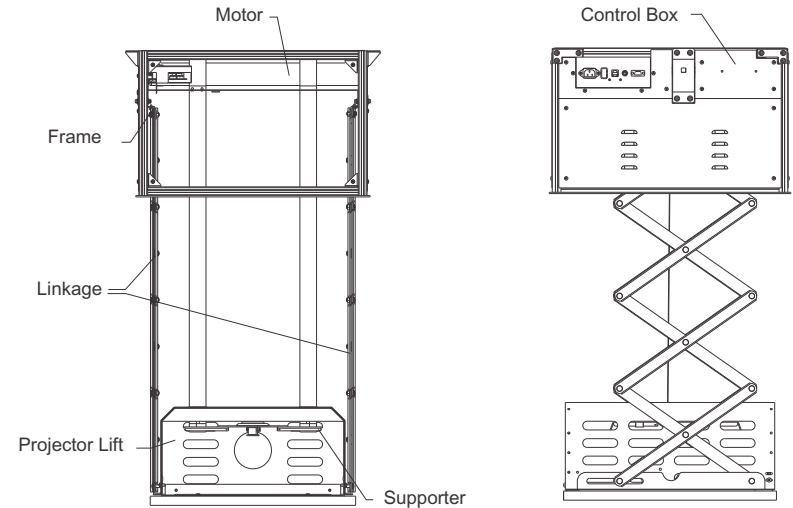

Front View

Side View

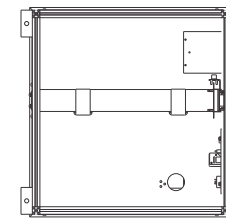

Top View

# Specifications

## Product Specifications

Model	Size(unit:mm)						
	A	B	C	D	E	F	G
GPCK-MB1000B	600	550	345	0-930	483	483	200

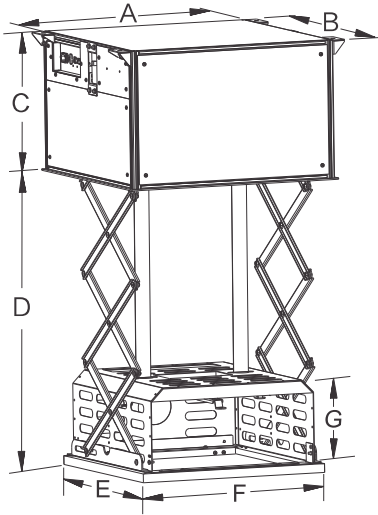

## Projector Lift Positioning Function

There are 2 solutions to position the projector lift, which are upper/lower limitation and remote localizer

### 1) Upper/Lower Limitation Adjustment for Sling Wires

Upper limitation and lower limitation are preset in factory, the upper limitation should be a little higher than ceiling, lower limitation is showed as numerical value D in the specification table (the upper/lower limitation for sling wire have to be regulated by professional people or dealers. Improper regulation will cause the risk of dangers)

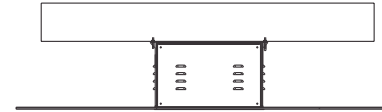

figure 12

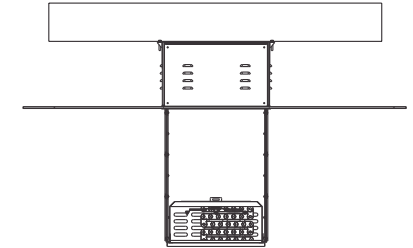

figure 13

**⚠** The following operation must be controlled by professional people

- For upper limitation adjustment, take off the knob from the hole and use the provided allen key to adjust. A clockwise adjustment will retract the projector lift (the distance of installation position of casing will decrease) and a counter-clockwise adjustment will extend the projector lift (the distance of installation position of casing will increase)
- For lower limitation adjustment, take off the knob from the hole and use the provided allen key to adjust. A clockwise adjustment will extend the projector lift (the distance of installation position of casing will increase) and a counter-clockwise adjustment will retract the projector lift (the distance of installation position of casing will decrease)

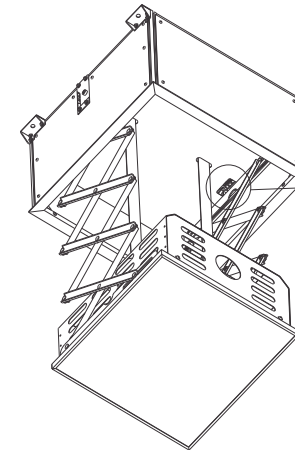

figure 14

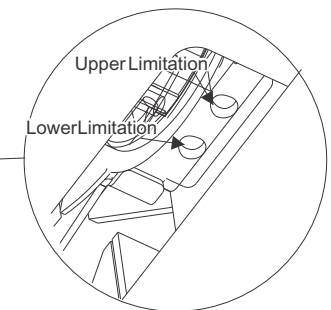

figure 15

Connect the power for projector lift A, and send out directive 0xFF 0x10 0x11 0x12 0xAA. At the same time, the address of projector lift A is 0x10 0x11 0x12. Entering the operating address of projector lift A can control this projector lift.

Directive for retracting: 0xFF 0x10 0x11 0x12 0xC9

Directive for stopping: 0xFF 0x10 0x11 0x12 0xCC

Directive for extending: 0xFF 0x10 0x11 0x12 0xE9

Completed the studying in projector lift A, and then disconnect the power for projector lift A. Please operate the projector lift B in the same way and change the address to 0xAA 0xAA 0xAA. Entering the operating address of projector B can control this projector lift.

Directive for retracting: 0xFF 0xAA0xAA 0xAA 0xC9

Directive for stopping: 0xFF0xAA0xAA 0xAA 0xCC

Directive for extending: 0xFF0xAA0xAA 0xAA 0xE9

This studying is one address bit for a long time until next address bit change to update.

After studying address bit, the common directive is still effective, so the address bit can not be 0xEE 0xEE 0xEE.

#### Attachment 1

Compare 16 hexadecimal system and 10 hexadecimal system

16 hexadecimal system	1	2	3	4	5	6	7	8	9	A	B	C	D	E	F
10 hexadecimal system	1	2	3	4	5	6	7	8	9	10	12	13	14	15	16

#### 4. Remote Controller Instruction

There is matching function between controller and projector lift, and then the controller needs to be programmed before using.

- 1) The projector lift is at situation of load. After connecting the power within 5 seconds, please press UP button and stop button simultaneously for 5 second then release
- 2) Press DOWN button to ensure whether the programming works
- 3) If the programming fails, please repeat step 2 and 3

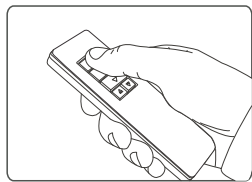

figure 10

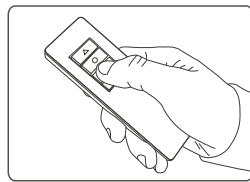
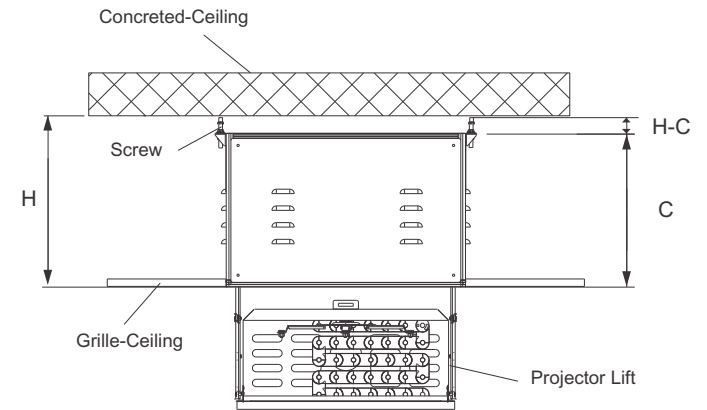

figure 11

## Installation

This projector lift needs to be recessed into the ceiling, and this instruction shows us the grille-ceiling as the example. Please install the projector lift according to different application. The projector lift needs to be recessed at the best viewing angle in order to improve the image. Take out all the parts from the packaging and follow the accessories guideline to ensure you have all parts.

\* For the convenience and safety, please read this instruction manual carefully and choose a installation according to your requirement.



#### Grille-Ceiling Mount

1. Choose a position according to the required space, and then take apart the ceiling (figure 1). Please measure the distance H between roof and ceiling surface correctly (figure 2)

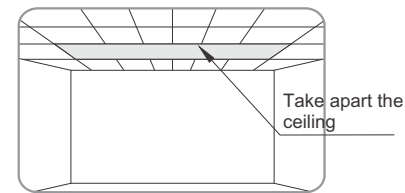

figure 1

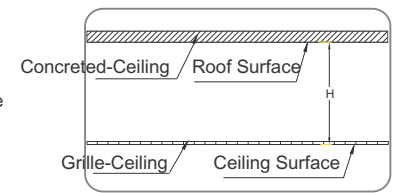

figure 2

2. Ensure the security distance M、N according to the figure 4 and the model of table. Install the brackets to the roof via the screws, figure 5.

(note: Due to product updates, sizes and specifications are subject to change at any time)

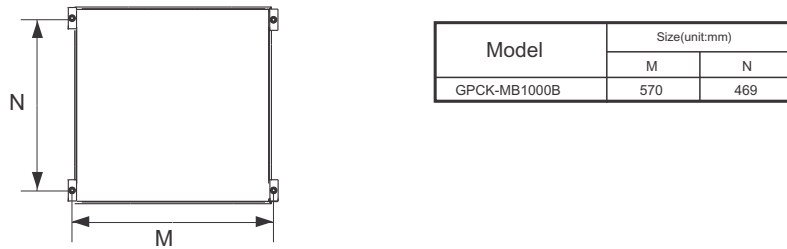

figure 3

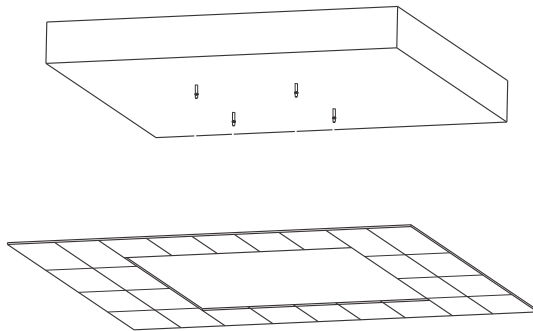

figure 4

## Grandview Projector Lift RS485 Setting Address

### 1、RS-485, RS-232 input

A continuous data sends two times, each time interval of 200ms

3 bytes of studying address directive are custom setting address directive

Central Control Format Agreement

1)Communication Agreement Setting

Data Bits: 8 bits

Start Bits: 1 bit

Stop Bits: 1 bit

Baud Ratio: 2400

Common directives are in chip of projector lift and can not be changed

2) Directive for retracting : 0xFF 0xEE 0xEE 0xEE 0xC9

3) Directive for stopping : 0xFF 0xEE 0xEE 0xEE 0xCC

4) Directive for extending : 0xFF 0xEE 0xEE 0xEE 0xE9

5) Studying address directive: 0xFF 0xXX 0xXX 0xXX 0xAA

### 2. Directive Composing Instruction:

0xFF is only bit; 0x stands for hexadecimal system; FF is effective bit; a directive is composed by 5 bits.

Studying directive 0xFF 0xXX 0xXX 0xXX 0xAA

0xFF and 0xAA can not be changed, but 0xXX 0xXX 0xXX can be changed to any 16 hex data, which stand for address bit

The changed working directive

1) Directive for retracting: 0xFF 0xXX 0xXX 0xXX 0xC9

2) Directive for stopping: 0xFF 0xXX 0xXX 0xXX 0xCC

3) Directive for extending: 0xFF 0xXX 0xXX 0xXX 0xE9

4) Studying address directive: 0xFF 0xXX 0xXX 0xXX 0xAA

Example: The studying directive is 0xFF 0x10 0x11 0x12 0xAA which can be changed to:

5) Directive for retracting: 0xFF 0x10 0x11 0x12 0xC9

6) Directive for stopping: 0xFF 0x10 0x11 0x12 0xCC

7) Directive for extending: 0xFF 0x10 0x11 0x12 0xE9

8) Studying address directive: 0xFF 0x10 0x11 0x12 0xAA

### 3. Studying Directive and Operation

After connecting power, studying status will operate within the first 10 seconds. The studying directive is 0xFF 0xXX 0xXX 0xXX 0xAA. The screen can be used normally after study completed, but the projector lift can not be used normally after the address bit changed, so that one port can be used to control many projector lifts.

Example:

There are projector lift A and B with RS-485 port, if need to control these two projector lifts synchronously that the directive 0xFF 0xEE 0xEE 0xEE 0xDD will be sent out from the port. If need to control these two projector lifts in different movement, such as projector lift A goes down and projector lift B goes up, common directive can not be used and separated by address bit at this time.



## Central Control Instruction

### Emitter Function

1	Common Line	5	Switch for Retracting
2		6	Stop
3		7	RS232 Input B
4	Switch for Extending	8	RS232 Input A

### Central Control Format Agreement

#### 1) Communications Agreement Setting :

data bits: 8 bits, start bits : 1 bit, stop bit: 1bit, baud ratio: 2400

2) Directive for retracting : 0xFF 0xEE 0xEE 0xEE 0xC9

3) Directive for stopping : 0xFF 0xEE 0xEE 0xEE 0xCC

4) Directive for extending : 0xFF 0xEE 0xEE 0xEE 0xE9

232 setting: 2400, n, 8, 1 a continuous data sends two times, each time interval of 200ms.

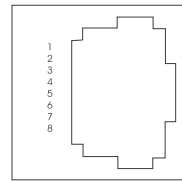

Crystal Socket

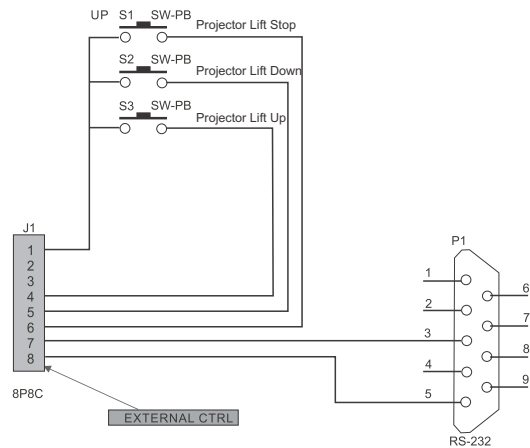
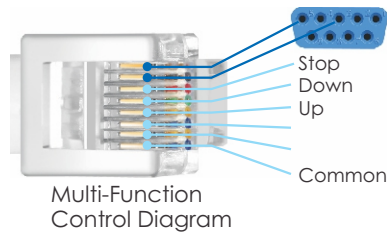

3. Figure 6, install the projector lift and fasten. The low frame of projector must align to ceiling.

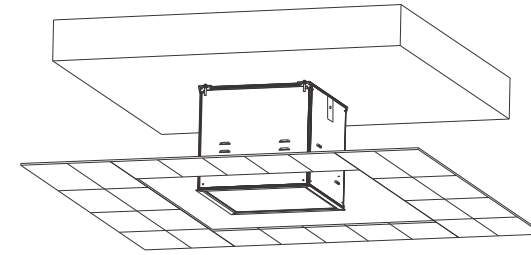

figure 5

4. Figure 7, check about the balance of projector lift

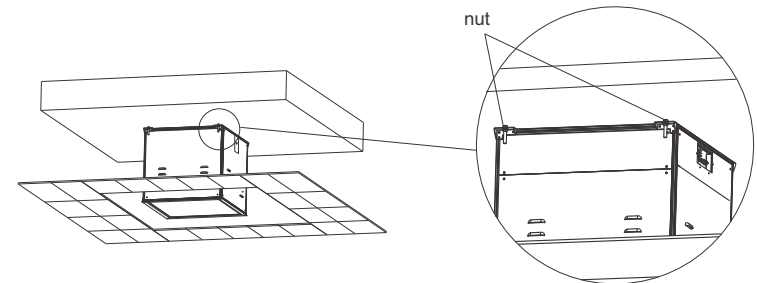

figure 6

5. Figure 8, connect the power cord and signal cord (Circuit wiring diagram 9)

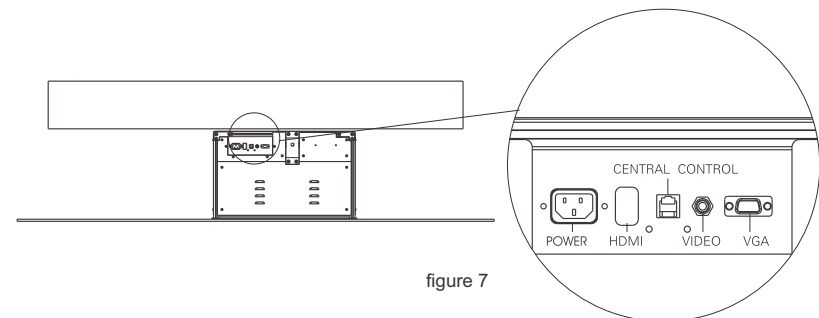

figure 7

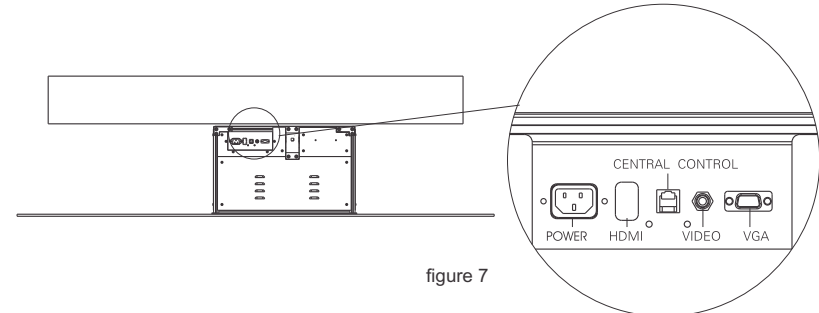

figure 7

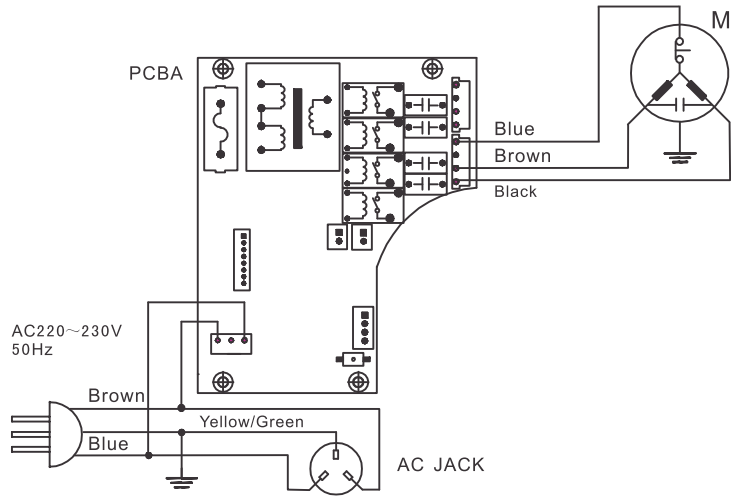

figure 8

6. Cut the ceiling board(Step 1)to a suitable size,which can maintain the gap after retracting of the projector lift

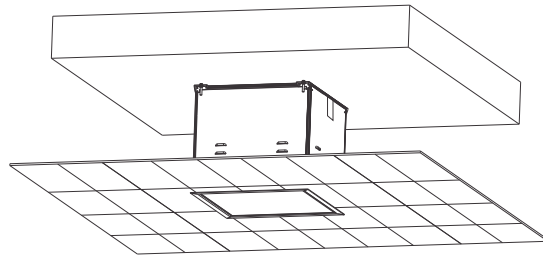

figure 9

7. Please read the 《Remote Electric Positioning》 for controlling the projector lift. After the adjustment, ensure the height of projector lift can satisfy your requirement after extending. And then, ensure the bottom of projector lift must align to the ceiling after retracting. Note: the operating must be controlled by professional people.

## Electricity

AC: 230 v 50Hz  
170W (0.7A)

## Instruction

### 1.Remote controller instruction

Button instruction for controller

1. Press "UP" , projector goes up
2. Press "STOP" , projector stops
3. Press "DOWN" , projector goes down

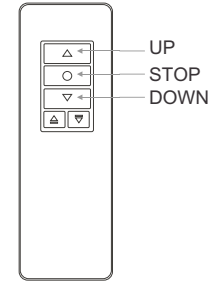

Front view

Remote controller guideline:

1. Work temperature: -20°to 70°
2. Batteries: 1.5V x 2pcs, model: AAA.
3. Take out batteries if the controller will not be used for a long time.
4. Please change the batteries when signal is weak.

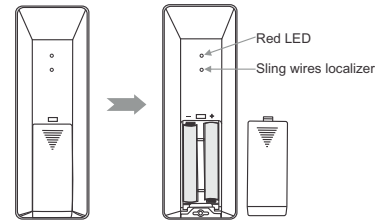

Back view

Installation for controller batteries

Please replace the batteries when the signal of controller is weak

1. Push out the battery cover on the back of controller
2. Install the batteries as guide arrow
3. Reinstall the battery cover

Caution

Install the batteries correctly

### Wall-Switch Function

Please follow the signs and symbols on the wall-switch

